

Opportunities and Challenges in publishing Biospecimen Science



Pierre Hainaut
International Agency for Research on Cancer
World Health Organization



International Agency for Research on Cancer
Centre International de Recherche sur le Cancer

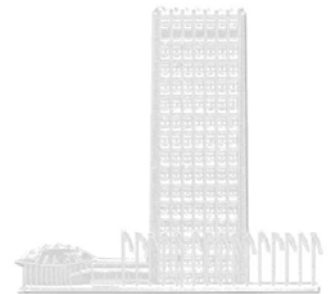

Outline

- What is « biospecimen science »?
- How publication may help structuring biospecimen science?
- How biospecimen science may uniquely contribute to biomedical science?
- How to enhance visibility and impact of biospecimen science?

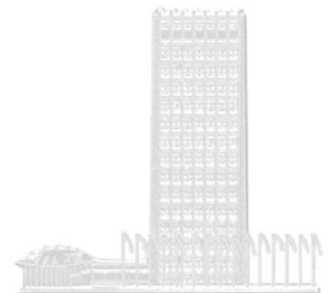

Take home message



"This company needs young brains like yours."



International Agency for Research on Cancer
Centre International de Recherche sur le Cancer

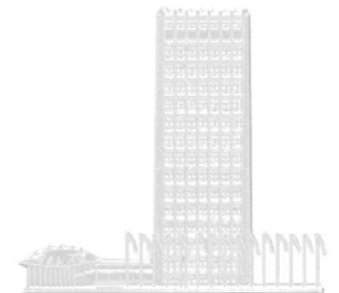

Biospecimen science

Scope of Biobanking activities

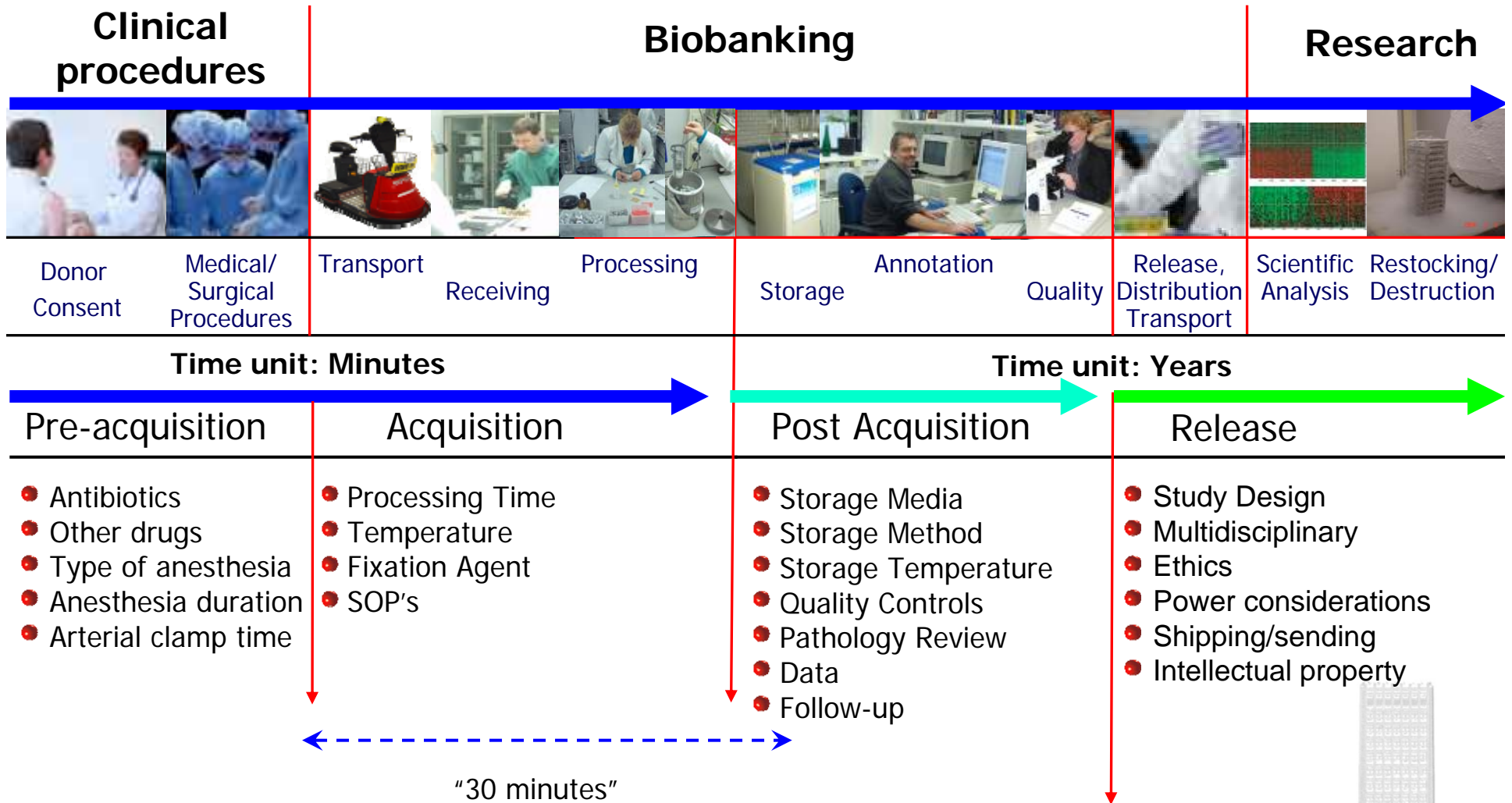

International Agency for Research on Cancer
 Centre International de Recherche sur le Cancer

Jim Vaught, Manuel Morente, Peter Pierman
 and the Marble Arch Interest Group



Biospecimen science: building instruments for discovery



International Agency for Research on Cancer
Centre International de Recherche sur le Cancer

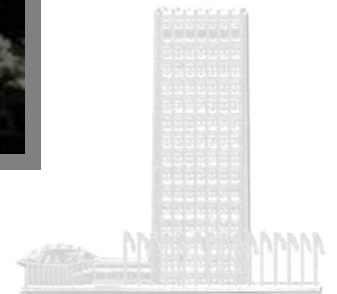

Very Large Lenses: High-density arrays

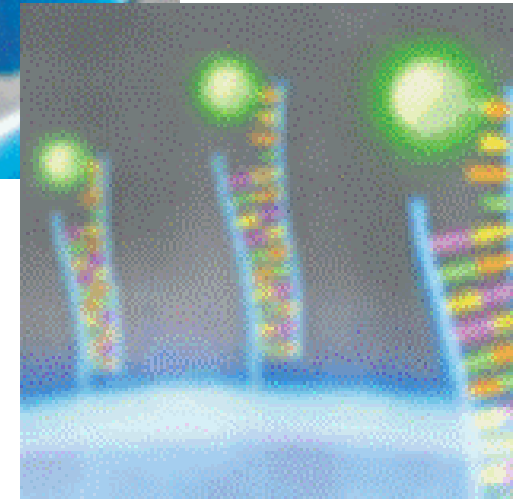
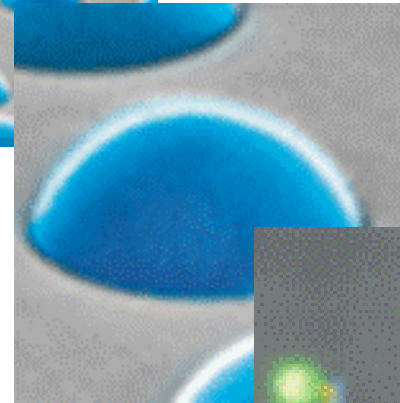
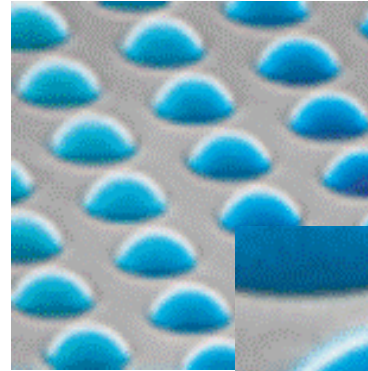
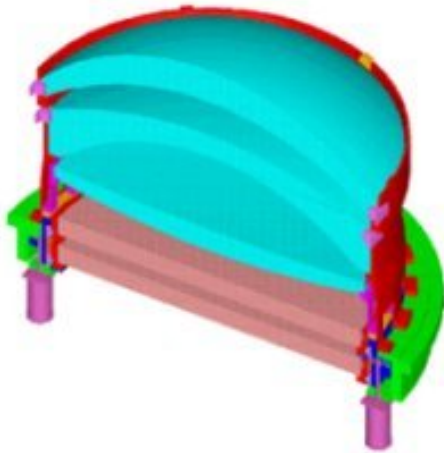

International Agency for Research on Cancer
Centre International de Recherche sur le Cancer



What you see depend upon instrument structure



International Agency for Research on Cancer
Centre International de Recherche sur le Cancer

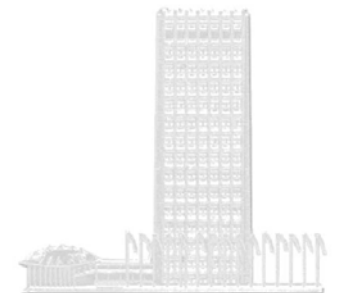

Standards, guidelines, operating
procedures, evidence-based
protocols and technical advances

Biobank Work Process

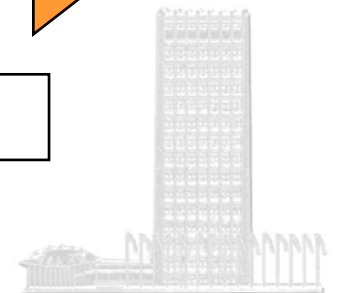
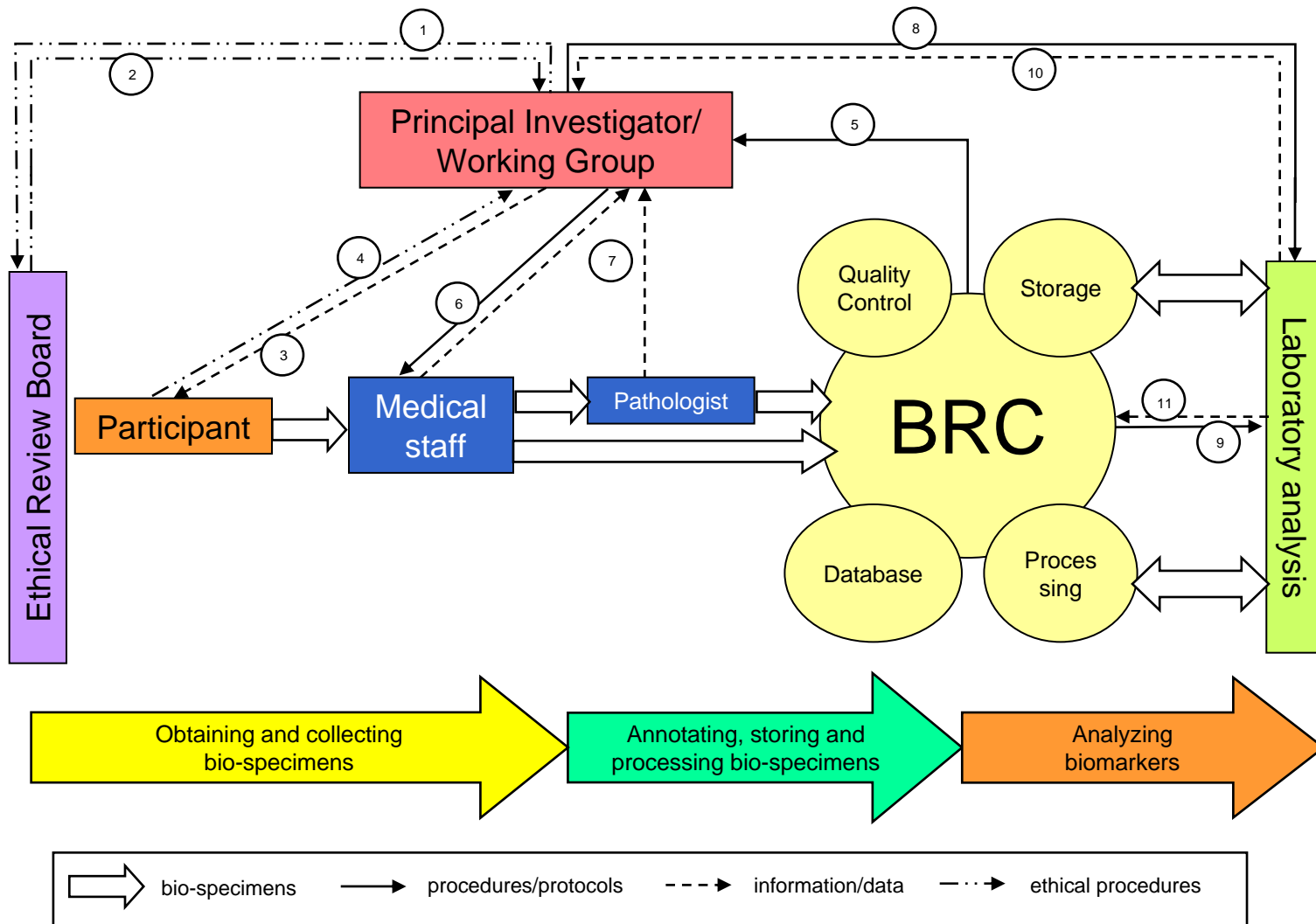

Technical Standards and SOPs for BRC

Title	Organisation	Link
Tissue banking for Biomedical Research	National Cancer Centre	http://www.bioethics-singapore.org/resources/pdf/AppendixB-Dr%20Kon.pdf
Biorepository Protocols	Australian Biospecimen Network (ABN)	http://www.abrn.net/pdf/ABN_SOPs_Review_Mar06_final.pdf
Biological Resource Centres: underpinning the future of life sciences and biotechnology	Organization for Economic Co-operation and Development (OECD)	http://wdcm.nig.ac.jp/brc.pdf
OECD best practice guidelines for biological resource centres	Organization for Economic Co-operation and Development (OECD)	http://www.oecd.org/document/36/0,3343,en_2649_34537_38777060_1_1_1_1,00.html
European Human Frozen Tumor Tissue Bank TUBAFROST	The European Human Tumour Frozen Tissue Bank (TUBAFROST)	http://www.tubafrost.org
Common Minimal Standards for Biological Resource Centers	International Agency for Research on Cancer (WHO)	http://www.iarc.fr/en/Publications/PDFs-online/IARC-Working-Group-Reports/Common-Minimum-Technical-Standards-and-Protocols-for-Biological-Resource-Centres-dedicated-to-Cancer-Research
Human tissue and biological samples for use in research. Operational and ethical guidelines	Medical Research Council (MRC)	http://www.mrc.ac.uk/pdf-tissue_guide_fin.pdf
Best Practices for Repositories I: Collection, Storage, and Retrieval of Human Biological Materials for Research	International Society for Biological and Environmental Repositories (ISBER)	http://ehs.sph.berkeley.edu/Holland/Biorep/BestPractices2005.3.5.pdf
First-Generation Guidelines for NCI-Supported Biorepositories	National Cancer Institute (NCI)	http://biospecimens.cancer.gov/practices/
Specimen Collection, Preparation, and Handling	Labcorp	http://www.labcorp.com/datasets/labcorp/html/frontm_group/frontm/section/speccol.htm



International Agency for Research on Cancer

Centre International de Recherche sur le Cancer

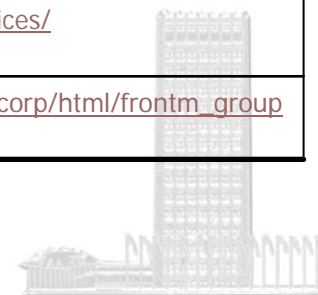



ISBER
says ...

P3G
says ...

IARC
says ...

BBMRI
says .

ISBER
says ...

BBMRI
says .

IARC
says ...

OBBR
says ...

P3G
says ...

OBBR
says ...

Forum for International Biobanking Organisations (FIBO)



International Agency for Research on Cancer

Centre International de Recherche sur le Cancer

OBBR

Office of Biorepositories
and Biospecimen Research



International Agency for Research on Cancer

Centre International de Recherche sur le Cancer

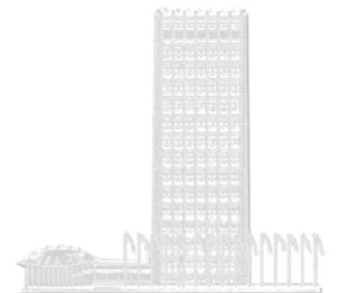

Evidence-based Protocols

“.....many protocols and guidelines reflect operational considerations for the establishment of biobanks: they emerge from striking a pragmatic balance between what is assumed to be the proper way to handle specimens and what is practically feasible in the field or in the clinics. It is now time to consider a paradigm shift in the approach to developing, implementing and evaluating biobanking standards and guidelines”



International Agency for Research on Cancer
Centre International de Recherche sur le Cancer

FIBO position paper, 2009



Evidence-based Protocols

- Making Best practices and guidelines available in a coordinated manner: library for protocols
- Designing, funding, developing and publishing research on evidence-based biobanking practices: Focus on pre-analytical procedures, stabilization and fixation, markers of biological quality/relevance



Minimal Reporting Dataset

- Study goals and design
- ELSI (Ethical, Legal, Societal Issues)
- Funding and Governance
- Source, storage, processing of specimens
- Pre-analytical processing
- Data management and access

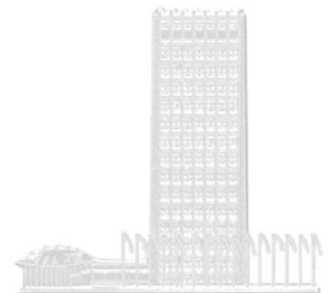

Biospecimen science as driver of
translational research on
biomarker discovery and validation

Biobanks in translational research

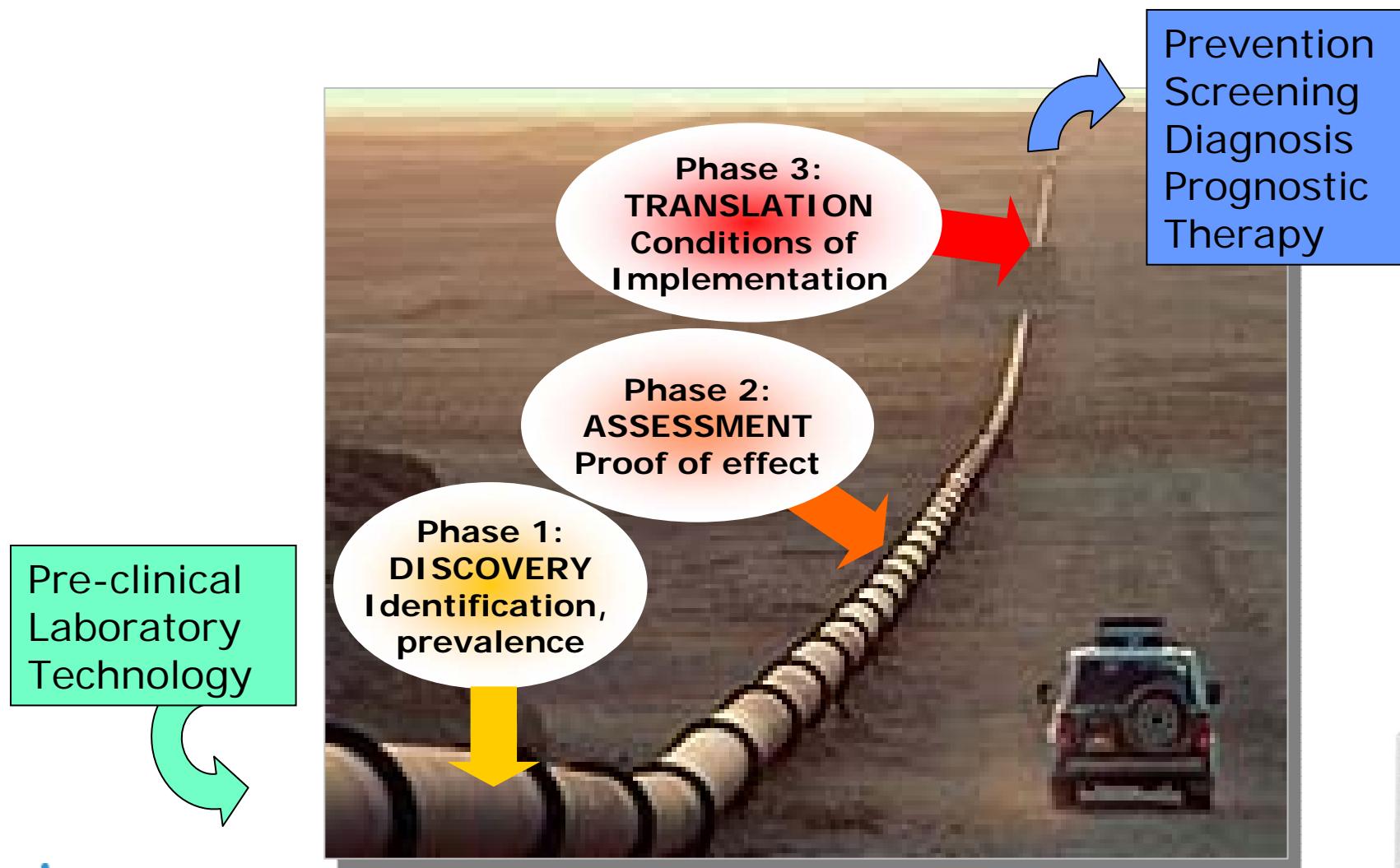

International Agency for Research on Cancer
Centre International de Recherche sur le Cancer

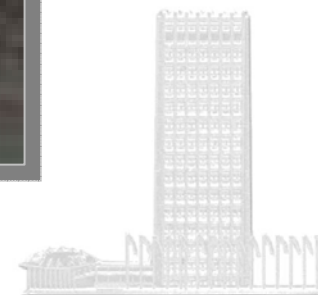

Biobanking needs according to phases of biomarker development

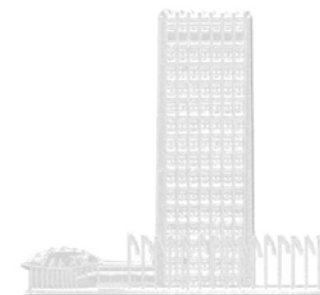
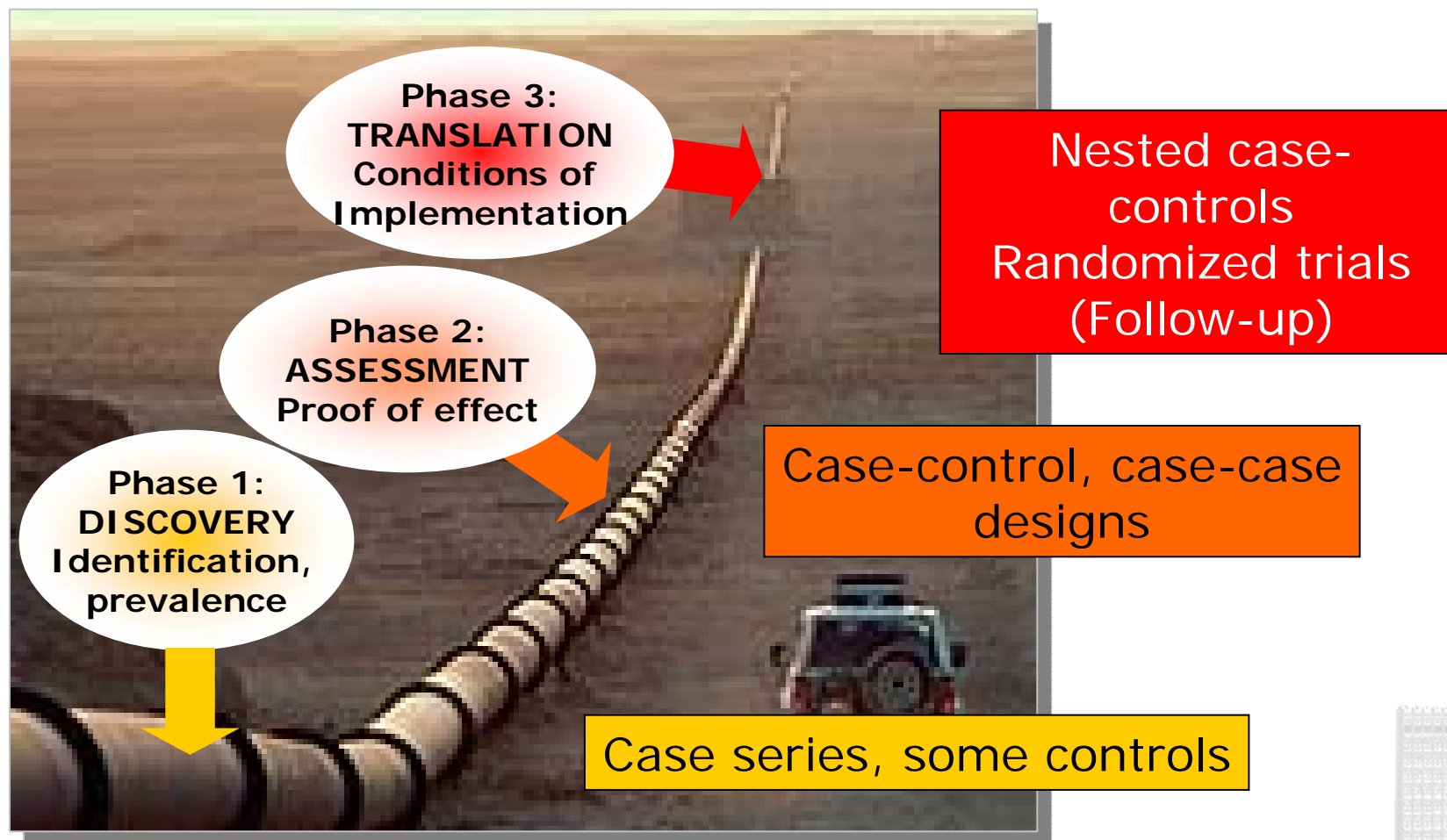

Intellectual challenges

- Does « retrospective design » really works?
- If not, what is the use of « un-designed » collections (e.g. most clinical biobanks)?
- Biobanking in clinical trials
- Innovative biobanking collection design, driving a new generation of « biomarker trials »

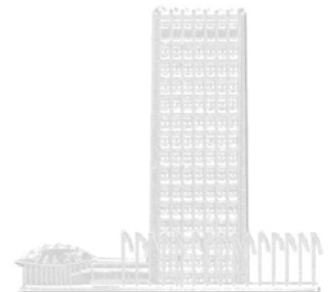

Unique contribution of
biospecimen science to frontline
biomedical research

Large-scale sequencing of the human cancer genome

- Analysis of 13,023 genes in 11 breast and 11 colorectal cancers revealed that individual tumors accumulate an average of approximately 90 mutant genes
- But that only a subset of these contribute to the neoplastic process.
- Using stringent criteria to delineate this subset, we identified an average of 11 per tumor that were mutated at significant frequency.

The consensus coding sequences of human breast and colorectal cancers. Sjöblom et al., Science 2006



International Agency for Research on Cancer
Centre International de Recherche sur le Cancer



Biospecimen science: shaping the future of biomedicine

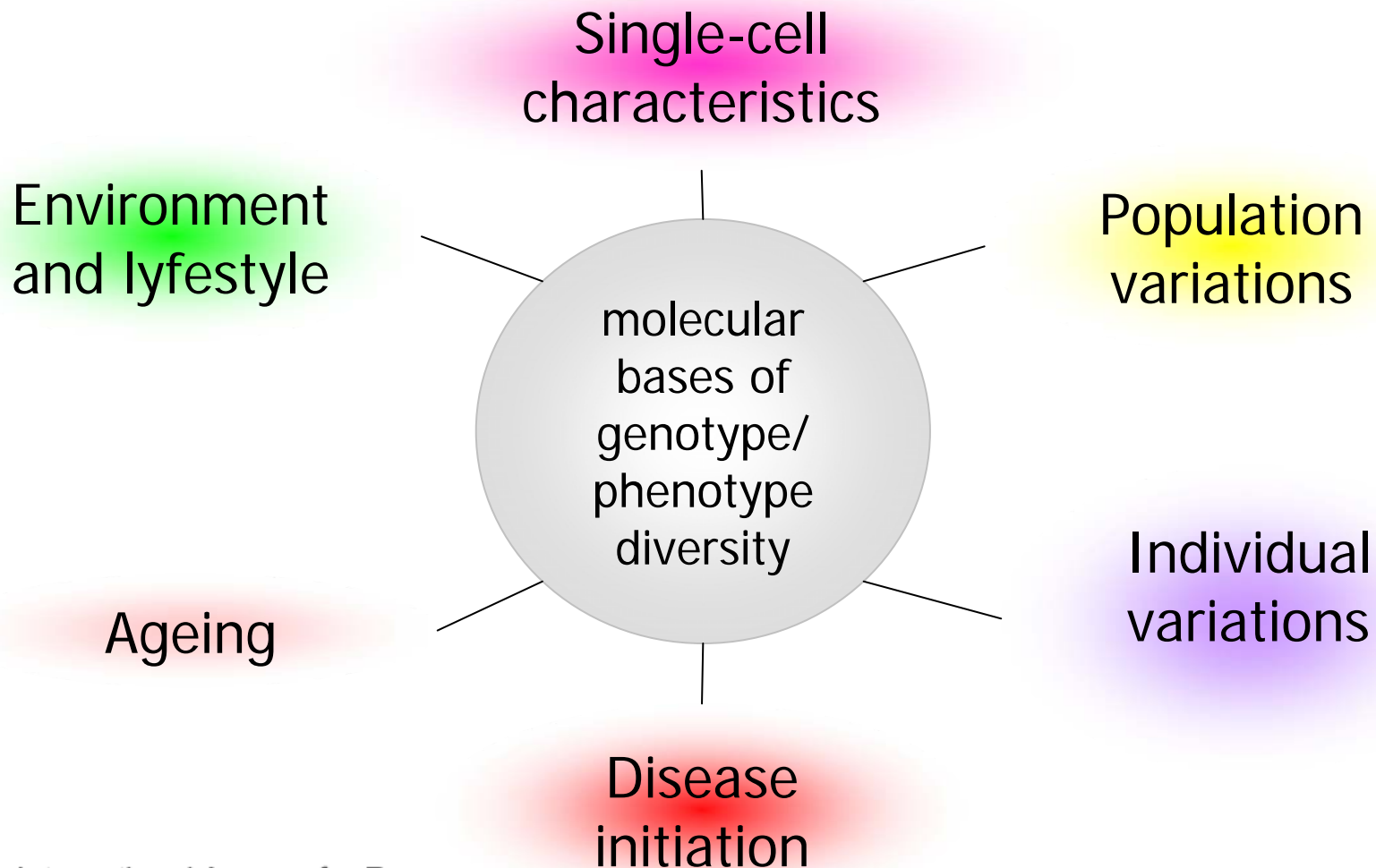

Increasing visibility and impact of
biospecimen science:
publication, training, networking

Publishing

- Biospecimen science as interface between scientists, physicians, patients and people
- High profile international journals focusing on biospecimen science
- Strong presence in mainstream journals in epidemiology, clinical sciences, genetics, etc...
- Publication initiatives targeted to scientific/medical communities: journal special issues
- Interactive publication «gateways » maintained by publishing companies with global outreach
- International competition/Prize in Biospecimen science



International Agency for Research on Cancer
Centre International de Recherche sur le Cancer





Application Notes
An extensive collection of technical performance of interesting new applications of laboratory technology suppliers.

Functional Glycomics Gateway
A collection of research data, data synopses, and news and even collaboration between the Consortium and NPG.

Neuroscience Gateway
An archive of research highlights and technique advances in neuroscience.

Nature Protocols
A new interactive online resource for high-quality laboratory protocols.

Nature Reports Stem Cells
A hub of information about the science, politics, ethics and clinical applications of stem cell research.

An extensive portal into publications relevant to large-scale biology from journals throughout NPG.

Nature Reports Climate Change
Nature Reports: Climate Change covers the news behind the science and the science behind the news of global climate change, arguably the most far-reaching challenge of this century.

Nature Network
NPG's free Web 2.0 toolkit connecting scientists worldwide — facilitating personal homepages, networking, online discussions, open or private groups and tagging.



International Agency for Research on Cancer
Centre International de Recherche sur le Cancer

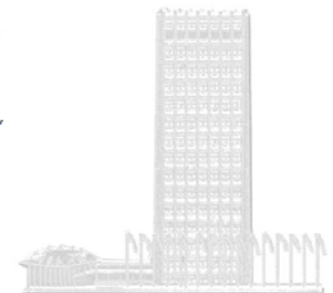

Training and teaching

- Introducing Biospecimen management courses in biomedical/bioscience teaching programs
- International courses in Biobanking
 - Common corpus of scientific knowledge and practice
- Curriculum in Biospecimen Science
 - Master Degree in Biospecimen Management
 - Doctorate (PhD) training

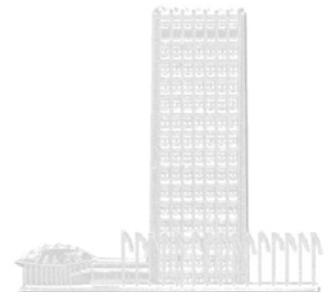

Networking

- Between biobanks: ISBER, Marble Arch
- International dimension: FIBO, P3G
- Involving stakeholders: patients/people, industry, public health community
- Sharing specimens, exchanges, sending and shipping: international protocol on biospecimen sharing for the global advancement of medicine

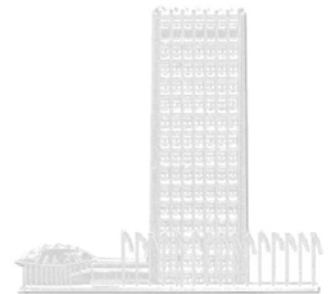

Worldwide diversity of disease patterns



International Agency for Research on Cancer
Centre International de Recherche sur le Cancer

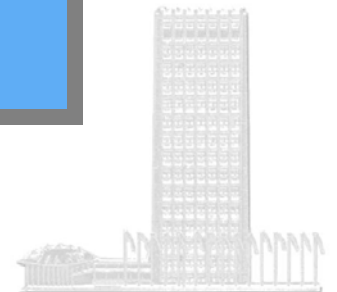

Networking: key to discovery for health



International Agency for Research on Cancer
Centre International de Recherche sur le Cancer



Further information

Biobanks at IARC

Elodie Caboux, BRC Manager, BRC@iarc.fr

Carole Cravotto, BBMRI and Biobank coordination

Dominique Bouchard, BRC secretary and administration

BRC staff (7 technicians)

Scientific supervision: Pierre Hainaut

Scientific strategy: Markus Pasterk

To receive a copy of these slides:

hainaut@iarc.fr

To access IARC technical guidelines:

<http://www.iarc.fr/IARCPress/pdfs/StandardsBRC/index.php>



International Agency for Research on Cancer

Centre International de Recherche sur le Cancer

